

**SUPER SEDAN SPECIFICATION MANUAL  
TABLE OF CONTENTS**

**SECTION 1 – Policy, Procedures, and Definitions**

- 1 INTERPRETATION**
- 2 GENERAL**
- 3 DECLARATION OF COMPLIANCE**
- 4 REGISTRATION**
- 5 MEASURING OF CARS**
- 6 PENALTIES**
- 7 AUTHORITY TO EXCLUDE**
- 8 SPECIFICATION BOOK TERM**

**SECTION 2 – Personal Safety Equipment**

- 9 DRIVER SAFETY**
- 10 PROTECTIVE CLOTHING**
- 11 SEAT BELTS**
- 12 INSTALLATION OF DRIVER RESTRAINT SYSTEMS**
- 13 ADJUSTMENT OF DRIVER RESTRAINTS**
- 14 WINDOW NET**
- 15 PADDING**
- 16 FIRE EXTINGUISHER**
- 17 SEAT**

**SECTION 3. – Class Specifications – Super Sedan**

- 18 DEFINITIONS**
- 19 SPECIFICATIONS**
- 20 CHASSIS AND ROLL CAGE CONSTRUCTION**
- 21 ANCILLARY BARWORK, PLATES AND BALLAST**
- 22 BODY SHAPE, DIMENSIONS AND BODY FITMENT**
  - General body fitment
  - Dimensions and measurement locations
  - Rear quarter window
  - Interior decking and firewall
  - Bonnet and Boot lids
  - Rear spoilers
  - Rub Rails
  - Towing attachments
  - Interiors and firewalls
  - Presentation and Signwriting
  - Front windscreen mesh
- 23 SUSPENSION**
- 24 ENGINE AND ENGINE SYSTEMS**
  - Engine options for Super Sedans
  - Engine block
  - Cylinder heads
  - Crankshaft and Conrods
  - Carburetor and Induction systems
  - Ignition
  - Fuel
  - Exhaust system
  - Cooling system
  - Engine Setback
- 25 TRANSMISSION, WHEELS AND TYRES**
- 26 BATTERY AND ELECTRICAL SYSTEM**
- 27 FUEL CELL AND FUEL SYSTEM**

**Super Sedan Specification Manual**  
**SECTION 1 – Policy, Procedures and Definitions**

**1. INTERPRETATION**

Speedway Sedans Australia Inc. (SSA Inc.) shall be directly responsible for the enforcement of these specifications. The Super Sedan Class Technical Advisory Committees (CTAC) is a sub-committee of Speedway Sedans Australia and is responsible directly to the SSA board. The role of the CTAC is to formulate a specification manual and provide clarification of rulings for the Super Sedan competitors and officials. Amendments to this specification manual may be made during the life of this manual for the reasons as set down in SSA Inc. Policy governing such amendments. Recommendations for an amendment will be submitted by the CTAC for submission to the SSA Inc. Board for approval. Amendments approved by the SSA will be circularized to all clubs, competitors and be displayed on the SSA website. All technical enquiries must be directed through your Club Scrutineer, State Technical Delegate and/or your State Office. SSA Inc. vehicles must only compete with SSA Inc. registered vehicles and with drivers who hold a SSA Inc./ Speedway Australia licence and SSA Inc. approved insurance and SSA Inc. Infringement card.

**2. GENERAL**

All new and existing cars must comply with all specifications detailed below. If "IT" is not in the book, it will be considered illegal until written approval is issued by the SSA National Office after ratification by SSA Inc. Board. Prior to constructing cars of an unusual or unconventional design, full details should be submitted in writing to the SSA Inc. Secretary. Any submission shall be handled in a confidential manner and approval, or required modification before approval, shall be given in writing to the applicant. An administration fee applies.

**3. DECLARATION OF COMPLIANCE**

The Owner of the car shall complete a SSA Inc. DECLARATION OF COMPLIANCE annually. Compliance Declaration will include:

SAFETY- compliance with all safety requirements  
ELIGABILITY- Compliance with all manufacturing specifications  
ENGINE- Compliance with Super Sedan engine specifications

Copies of the declarations of compliance are to be placed in the logbook. An additional Declaration must be completed by the owner and be placed in the Log Book following any chassis or engine repairs that result in a change to the original declaration.

**4. REGISTRATION**

An annual car registration shall only be issued subject to the car conforming to all specifications detailed in the SSA Inc. Specification Book for the Super Sedan Class and Declaration of Compliance being provided. Registration is not complete until Pages 3 to 6 of the LOG BOOK are completed and signed by both the Owner/Driver and the Scrutineer/Machine Examiner or Registrar. The car must be re-examined as a minimum on an annual basis to confirm compliance and a new Declaration of Compliance produced. A new registration decal will be issued annually and must be attached to a prominent location on the car. The OWNER is responsible for ensuring that the logbook and Declaration of Compliance are completed before participation in any official practice session or race meeting. The log book must be endorsed by the Machine Examiner at each meeting prior to competing.

## **5. MEASURING OF CARS**

All cars are subject to engine checking and general measurement at any time by a duly accredited Scrutineer, the National Technical Director, the National Technical Committee, the Steward or the Racing Disputes Committee. The SSA Inc. reserves the right to inspect any racecar at any time, including the downloading of any information via any means.

The owners of the cars must deliver them immediately upon request and supply the necessary manpower and hand tools to accomplish dismantling. Only persons actually involved in dismantling the car will be allowed in the immediate area of a vehicle being checked. Any persons not having cars in the impound area, and gaining entry without authorisation, will be ejected. If there are no facilities available to check any parts of a vehicle, sealing of parts under question can be carried out and vehicle taken to a mutually agreed venue for examination at another time, but within four (4) days.

Impounded cars will be stored at the owner's risk. Although every reasonable precaution will be taken, no responsibility for fire, theft or damage will be assumed by the SSA Inc. and/or affiliated clubs.

## **6. PENALTIES**

The Super Sedan Specification Manual must be read in conjunction with the Australian Speedway Racing Rules and Regulations and/or notices issued by the SSA Inc. from time to time. Ignorance of these Regulations and Specifications and notices shall be deemed as no defense in regard to breaches and/or appeals.

## **7. AUTHORITY TO EXCLUDE or INCLUDE**

If an SSA Inc. Official, including a duly accredited Scrutineer, the National Technical Committee, Steward, or the Racing Disputes Committee determines prior to the race that the Race Car does not meet the applicable specifications, the car will not be allowed to compete unless, at the discretion of the official, the deficiency:

- a. will not adversely affect the orderly conduct of the race.
- b. will not provide the competitor with a significant competitive advantage over other competitors.
- c. is so insubstantial as not to warrant a determination that the car is ineligible to race.

If the car is permitted to compete under these circumstances, the Official will advise the competitor in writing of the deficiency and the timeframe for correction of the deficiency. If the deficiency has not been corrected within the allotted timeframe, the car will be prohibited from competing in any future event.

## **8. SPECIFICATION BOOK TERM**

This specification book will be for a term of 3-5 years.

**Super Sedan Specification Manual**  
**SECTION 2 – Personal Safety Equipment**

**9. DRIVER SAFETY**

All protective clothing and safety equipment must be used and/or worn in the approved and accepted manner whilst competing, or testing and/or practice.

All race wear/equipment shall be inspected at each practice/race meeting.

Illegal parts or safety equipment will be confiscated and stored by State where event is being held.

**10. PROTECTIVE CLOTHING**

All Protective Clothing shall comply with minimum standards for Safety Apparel as specified in the Australian Speedway Racing Rules and Regulations.

**11. SEAT BELTS**

An approved type racing harness must be fitted, using a minimum of four major belts and four mounting points, plus one or two anti-submarine/crotch straps. Shoulder and Hip Belt width 50mm minimum, 75mm highly recommended. Only belts with over-centre lever lock buckle to be used.

**SEAT BELT LIFE IS A MAXIMUM OF TWO YEARS FROM DATE OF MANUFACTURE**

Shoulder belts are to have separate anchor points/adjusters.

Shoulder belt mounting points shall be positioned to the rear and below the point, at which the shoulder belts come through the seat and be not more than 300mm from that point, attached to 38x3mm CHS. See Fig 1

Lower seat belt mounting brackets (anchor points) must mount to roll cage and chassis or substantial bar work using a minimum construction of 25x25x3mm RHS or 25x3mm CHS or 32x32x2.5 RHS. Seat belt attachment tag shall be 3mm minimum mild steel.

Anchor bolts shall be 10mm steel minimum.

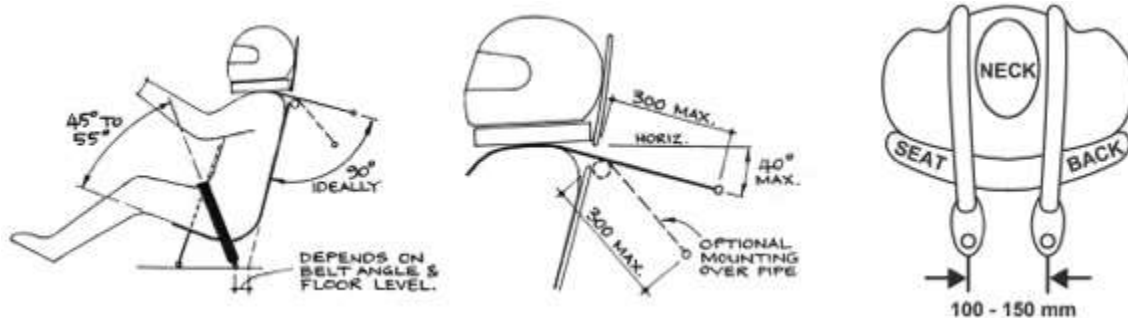

**Fig. 1**

**12. INSTALLATION OF DRIVER RESTRAINT SYSTEMS**

The mounting points must be solid and should remain so even if the vehicle is deformed due to an accident. The mounting points should also not put undue strain or twist on the belt system hardware. The lap belt should be positioned so it rides across the solid pelvic area and not the soft stomach area or down on the thighs. The shock absorbing ability of the pelvic area and its ability to protect internal organs make it the preferred location for the lap belt. See Fig 2 (i) & (iii).

The shoulder harness should be mounted to prevent driver's shoulders from moving forward (upward if semi-reclining), out of the seat, in the event of a rollover.

Anti-submarine straps serve two purposes;

1. To secure the lap strap down across the driver's hips, so in the event of an accident, it is not pulled up across the stomach by the shoulder straps.
2. To prevent the driver from sliding forward and out of the harness. When the driver is seated in an upright position, as in most sedans, a five point system (a single anti-submarine or crotch strap) is considered adequate (Fig 2 ii). For extra assurance a double strap anti-submarine belt can be used. (Fig 2 iv)  
When the driver is seated in a semi-reclining position a six point system (two anti-submarine or crotch straps) is preferable. Most drivers find the two anti-submarine strap system more comfortable. In many instances, the anti-submarine straps are mounted much too far forward of the seat. This practice could cause unnecessary injury as the body can slide partially out of the seat before being restrained when the strap contacts the groin. It is much more practical to cut a slot in the seat bottom so the anti-submarine strap can be anchored in line with the chest. (Fig 2 (i))

Because of the differences (often vast) in competition vehicles, a 'standard' method of mounting is impractical. Good judgement and common sense in inspecting restraint system mounts is needed. Safety equipment is often neglected in favour of performance equipment, but its proper operation when the need arises is essential to survival.

**Fig. 2(i)**

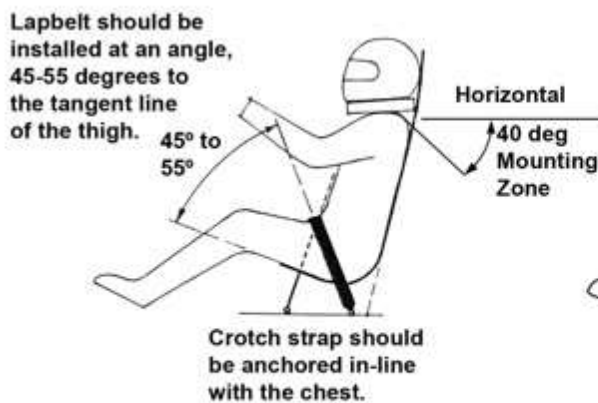

**Fig. 2(ii)**

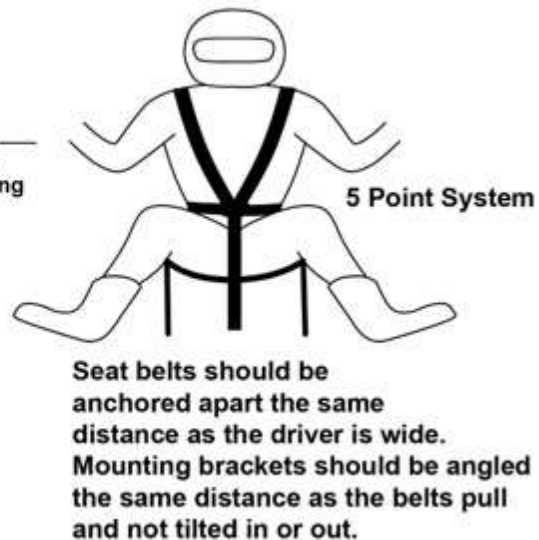

**Fig. 2(iii)**

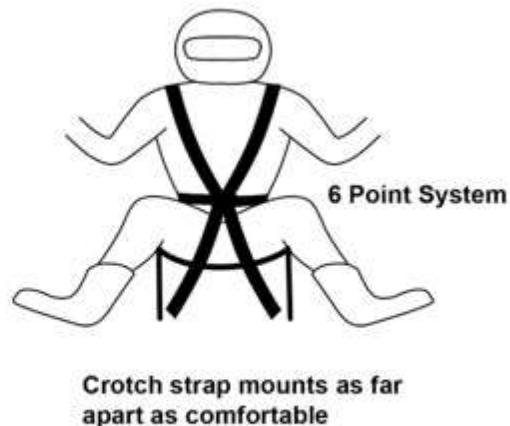

**Fig. 2(iv)**

### **13. ADJUSTMENT OF DRIVER RESTRAINTS**

With the driver fully kitted out in 'underwear and driving suit', check that, with the driver seated, belt slots in the seat line up with natural line of the belt from anchor to buckle when just the lap belt is tensioned. Ensure that the lap adjusters do not foul the seat and that they are readily accessible. Some belts adjust by pressure downward others by pull up. Check that the driver can manipulate belt adjusters with gloves ON.

Also check that anchor hardware is aligned and that it is not possible to have a hitch in the anchor area without detection (sudden release of the belts to 50mm slack can put the driver off-line).

Also check if the belt is holding the seat or the driver, it must be the latter.

Adjust the anti-submarine strap/s to ensure that the buckle is held flat and close to the body over the pelvis. When satisfied that the lap belt is OK, put on the helmet and check just how far the helmet (with visor) can reach, head plate clearance, helmet/window net etc. Slacken the seat belt, engage the shoulder belts into the buckle and tension the seat belts again, checking position of the buckle and adjusters. Tension each shoulder belt, checking that the adjustment range is suitable to the driver, that the belts and hardware don't foul the seat and that the natural line of the belts holds the driver as with the lap belts.

Note also any change in the buckle location and lay. If there is too much variation with the buckle it would appear that lap anchors are not in optimum position.

Before the driver releases the buckle, he should slacken both shoulder belts with the adjusters, in order to make re entry to the car and refitting of the seatbelts as simple as possible.

### **14. WINDOW NET**

The use of an SFI approved window net is mandatory.

Window net shall be minimum 19mm woven webbing with 75mm max hole size.

The window net shall be hinged from the bottom and shall be fixed at the top via a 6mm minimum rod threaded through the cavity provided. The rod shall be secured with lock pins or a central spring-loaded pin. Window net shall be secured to any combination of roof hoop bar, A pillar bar or the main hoop bar at the top. The Window net shall be secured to the top NASCAR bar at the bottom. Quick release seat belt type attachments are also permitted

### **15. PADDING**

Padding shall be used to protect driver from injury in the event of an accident. Cars shall be manufactured to minimise driver contact with sharp edges, projections or barwork in the cabin area.

### **16. FIRE EXTINGUISHER**

An on board fire extinguisher is permitted. It must be securely mounted and be suitable for the fuel being used.

### **17. SEAT**

A proprietary one-piece steel, aluminium or carbon fibre bucket type seat incorporating a substantial headrest shall be used. Aluminium and steel seats shall be constructed of a minimum 3mm material thickness. Fig. 3(i) Proprietary aluminium full containment seats shall be a minimum 2.5mm material thickness. Fig. 3(ii) Approved proprietary carbon fibre competition seats must use manufacturers mounting kits. Approved seats include Kirkey, Butler, United Speedway Accessories, Bratpac and Racetech.

Magnesium alloy seats not permitted.

Seat design shall provide Lateral (sideways) support to hips and chest.

As a minimum the seat shall support the drivers back to the top and full width of the shoulders.

The seat is to be mounted completely on the right hand side of the vehicle centreline.

The seat base is to be mounted to roll cage chassis at a minimum of two points using 8mm bolts and minimum of 40mm diameter body washers.

Seat back is to be braced and attached to the roll cage approx 75mm below shoulder height using a minimum of two 8mm bolts and 40mm body washers.

The driver shall have a minimum 50mm clearance between the helmet and the head plate/hoop bar when seated.

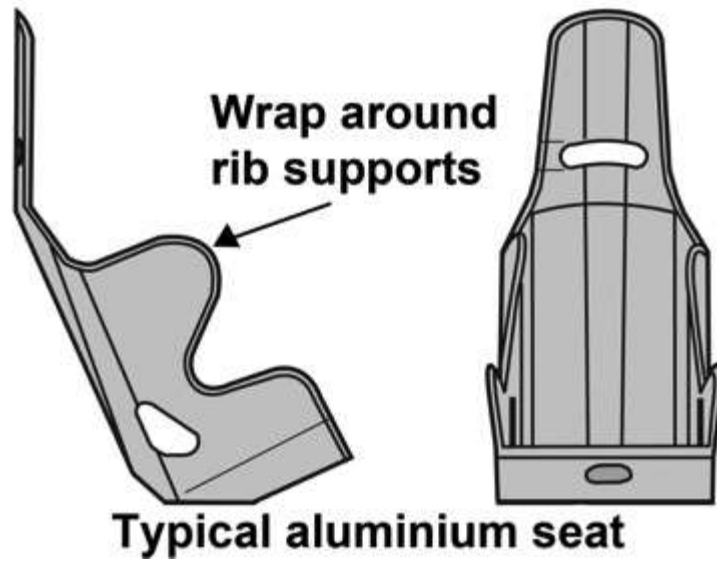
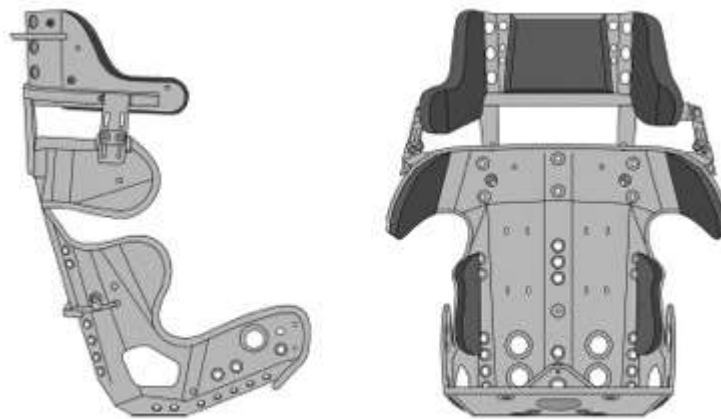

Fig. 3(i)



**Typical Full Containment type seat**

Fig. 3(ii)

**Super Sedan Specification Manual**  
**SECTION 3 – Super Sedan specifications**

**18. DEFINITIONS**

**Super Sedan**

A Super Sedan is a purpose built full chassis race car enclosed by a complete body. A Super Sedan shall also comply with the following:

1. right hand drive only,
2. engine in front of driver,
3. rear wheel drive only,
4. quick change differential or differential fitted with full floating rear axles.
5. independent front suspension
6. Wheel base 2540mm minimum, 2740mm maximum.
7. moulded plastic or fibreglass nose and tail panels.

**Wheel Base Measurement**

With each front wheel pointing straight ahead, measure distance from front axle centre to rear axle centre on each side of vehicle. Add dimensions for left and right and divide by 2.

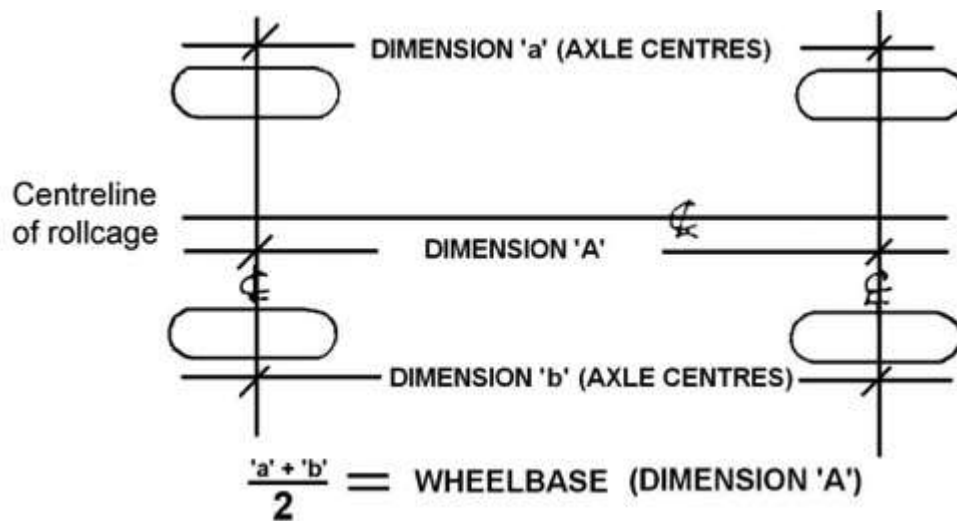

**Chassis Centre line**

Defined as the mid-point between the outside of both outriggers in the cabin chassis area. This is calculated by dividing the measurement between the outside edges of the two outriggers by two.

**Body Width Measurement**

Maximum 1960mm at waist height measured on the door panel immediately behind the front wheels and directly in front of the rear wheels

**Engine Capacity**

Determined by measuring the bore and stroke of the engine, calculating the swept volume of one cylinder and multiplying that figure by the number of cylinders in that engine.

Engine displacement = 0.7854 x bore x bore x stroke x no of cylinders.

**Bubble Testing**

Bubble testing will be an accepted method of measuring the cubic capacity of a super sedan engine to confirm compliance with the specifications. The owner of any bubble-tested engine that exceeds the 367ci limit (plus stated limits of accuracy of specific testing instrument) shall be given the opportunity to remove the head for physical measurement.

Cars shall be subject to bubble test at any time. If car is found to be over the limit with bubble test, the owner has the option to remove head for physical measurement purposes. Should the



physical measurement with the head removed also show an oversize engine, the competitor shall be penalized in accordance with the current Australian Racing Rules and Regulations.

### **Engine Setback**

Measured from the centre of both top ball joints to the rear mating face of the engine block. Either measurement shall not exceed the maximum allowed.

### **Blade**

The blade refers to the flat inclined surface of a wing. Maximum blade length (as measured from top of blade to bottom of blade) is 400mm. Maximum width of blade (side to side) shall be 1550mm.

### **Cabin Chassis Area**

Is the base of the chassis that the roll cage legs mount to and has a minimum floor area measuring 900mm x 1445mm.

### **Chassis**

The chassis is the 75x50x3mm minimum (sonic test at not less than 2.7mm w.t. ABSOLUTE) RHS frame that supports the body, engine and suspension components of an automotive vehicle.

### **Engine**

Includes all components that enables the engine to operate including bolt on components such as rocker covers and carburettor but excludes exhaust manifolds and radiator.

### **Inch**

1in = 25.4mm

### **Kilogram**

1kg = 2.2lbs

### **Material:**

CHS Circular Hollow Section.  
SHS Square Hollow Section  
FMS Flat Mild Steel  
RHS Rectangular Hollow Section.  
w.t. Wall thickness.  
O.D. Outer Diameter

## **19. SPECIFICATIONS**

### **General**

All workmanship shall be to a professional standard and all materials used shall meet the minimum standard specified.

All material sizes quoted are a minimum specification unless a maximum is stated.

No cabin adjustments allowed except for brake bias and brake shut off valve.

Adjustable timing devices and adjustable rev limiters are not allowed inside cabin area or where they can be adjusted by a driver.

No electric, electronic, hydraulic or wireless activated adjustments allowed except those specified for nonV8 ecu cars.

Rear Vision Mirrors or rear vision cameras with display are not permitted.

### **Weight limits**

Minimum weight including driver:

V8	1100 kg	(2420 lb)
6 Cylinder and Rotary	1000 kg	(2200 lb)

Vehicles shall be weighed at any time.

### **Maximum Body Width**

Maximum width of the body is 1960mm as measured at waist height immediately behind the front wheels and directly in front of the rear wheels

Maximum overall width of vehicle including wheels, plastic nose cones and fenders is 2110mm.

## 20. CHASSIS AND ROLL CAGE CONSTRUCTION

### Material thickness and tensile strength

All specified material used in the Roll cage and Chassis shall have a minimum tensile strength of 300MPa and a minimum wall thickness of 3mm (sonic test at not less than 2.7mm w.t. ABSOLUTE) after all fabrication and bending. This shall include but not be limited to manufacturing processes such as cutting, grinding, sandblasting, bending, stretching, welding, heating etc. Specified material includes any structural member specifically detailed in this document with a nominated minimum material size. All measurements for CHS relate to Tubing only (not pipe). Tube is defined as having an OD (outside diameter) and a w.t. (wall thickness)

### Sonic Test

Sonic testing to determine wall thickness shall be conducted on bare/unpainted steel members. Owner shall remove paint or powder coating as necessary to perform the test.

### Roll Cage

The roll cage is required to provide a safe enclosed environment for the driver and is intended to prevent the collapse of the cabin area under impact. The roll cage is to fully enclose the driver. The roll bars are to constitute a cage type framework, braced fore and aft. The cage must extend from behind driver's seat forward to the windscreen area and incorporate protection for the driver's feet.

Roll cage is to be symmetrical about a common centreline through the front chassis rails and cabin chassis area and be full height of the cabin chassis area. Rear rail lateral location shall be placed at manufacturers discretion. The minimum distance between the rails shall be 736mm (29 inches) All roll bar material must be mild steel, minimum 38x3mm CHS.

All bends to be made using a bender with the correct size former. All bar work shall be inside the body. Roof area of the cage shall be a minimum 765mm long and 1065 mm wide as measured to outside of roof hoop bar. Floor area shall be minimum 900mm x 1445mm.

The following drawing details the minimum structural requirements. Each item number is referred to in the text below.

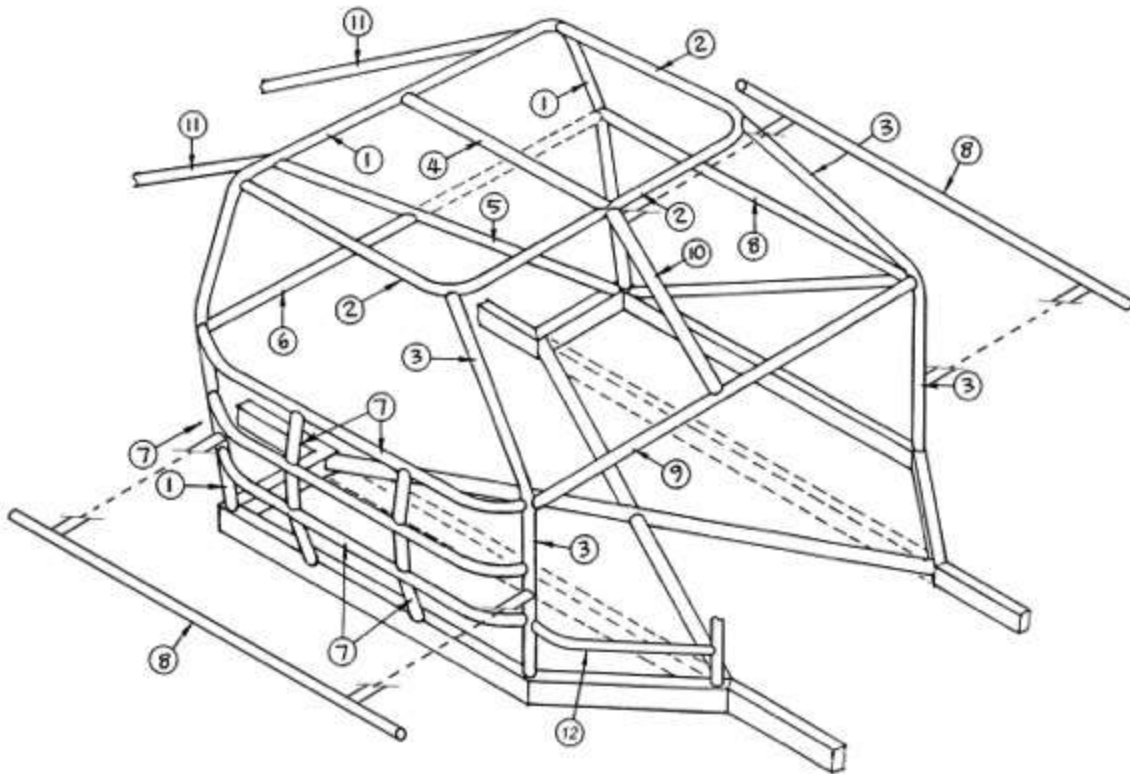

Note. Drawing for display purposes only. Refer to text for clarification on all drawings

- (1) **Main hoop** - The rear main hoop shall be formed from one continuous length of 38x3mm minimum tubing with smooth continuous bends and no evidence of crimping, wall failure or significant weakening. Rear main hoop to be welded to the top of chassis outriggers. The rear main hoop may slope back away from vertical a maximum of 15 degrees.
- (2) **Roof hoop** – The roof hoop shall be formed from one continuous length of 38x3mm minimum tubing and be welded to the main hoop to form a halo around the driver's head. Alternatively, the roof hoop may be replaced by using one continuous piece of tube to form the front leg and A pillar which then continues back to the main hoop. The alternate roof hoop shall be completed by the installation of a spreader bar across the top of the windscreen.
- (3) **Front legs** – Two front legs are to be formed each from a continuous length of 38x3mm minimum tubing and be welded to the chassis outriggers at the bottom and front corners of the roof hoop at the top. The 'door pillar' part of the front legs must not be flatter than 45 degrees. The minimum distance between the front leg and the rear main hoop where they connect to the chassis outrigger shall be 900mm. This is measured outside to outside of the front leg and the rear main hoop bars.

OPTION: Rather than using a main roof hoop and two front legs, one continuous roof hoop and one continuous shoulder hoop can be used. The shoulder hoop shall incorporate the top NASCAR bar, lower windscreen bar and passenger top NASCAR bar. This means that the A pillar bar to be formed in two pieces; one joining the chassis outrigger to the shoulder hoop and one joining the shoulder hoop to the roof hoop.

- (4) **Centre roof bar** - Centre roof bar shall be minimum 32x3mm mild steel and shall be welded between the main hoop and the roof hoop.
- (5) **Rear diagonal** - A one piece diagonal brace, minimum 38x3mm CHS will be fitted in the main roll cage hoop behind the driver's head, within 250mm of the corner and down onto the left side chassis rail or roll cage leg. (Top right to Bottom left)

A second brace may be fitted in cruciform. If a cruciform type bracing is used a minimum of 32x3mm CHS may be used.

- (6) **Seat back support/shoulder belt mounting bar**- The anchor point mounting bar, minimum 38x3mm CHS, for the shoulder belts shall be positioned so that belts are anchored a maximum of 300mm from the rear of the shoulder belt opening of the seat.
- (7) **NASCAR bars**- NASCAR bars shall be fitted to the driver's side between the down leg of the main hoop and the front leg. The NASCAR bars shall consist of three horizontal side bars, curved out toward the door skin. One of the three bars may run straight through from the front wheel arch to the rear wheel arch and shall have two separate pieces 38x3mm turning at 90 degrees to connect onto the front leg and rear main hoop. There shall be a minimum of two bars evenly spaced between front leg and main hoop bar for each of the openings created by the horizontal NASCAR bars making a minimum of six bars to be fitted. Eg. Minimum 2 vertical bars between the top NASCAR bar and the NASCAR bar and the middle NASCAR bar, minimum 2 vertical bars between the middle NASCAR bar and the bottom NASCAR bar and a minimum of 2 vertical bars between the bottom NASCAR bar and the outrigger.
- (8) **Door bars** – Passenger side shall have a minimum of two bars between front and rear roll cage legs. The top one must be horizontal and be the same height as top drivers side NASCAR bar. The second one must be waist height. Diagonal bracing in the passenger door area is optional. The driver's side door bar must be waist height. Door bars shall be maximum 38x3mm CHS.
- (9) **Lower windscreen and dash bar** - Lower windscreen and dash bar shall be a horizontal bar joining the front cage legs at top door bar and top NASCAR bar height. As an option, the lower windscreen bar can extend in one continuous length to incorporate the top NASCAR bar, lower windscreen bar and passenger top NASCAR bar.

- (10) **Centre windscreen bar** - Centre windscreen bar, 25x3mm CHS mild steel.
- (11) **Rearward brace bars** - Rearward brace bars minimum 38x1.6mm CHS to extend from the top rear of main hoop down onto rear chassis rails (Maximum 45 degrees down from vertical). They may form a crucifix and must be attached to the rearward side of the main hoop within 250mm of the centre of the bend.
- (12) **Foot protection bar** – Foot protection bar minimum 38x3mm mild steel CHS to extend from drivers side front leg around to engine support bar or front chassis rail. The foot protection bar shall provide maximum protection to the driver's feet and legs in front of the foot well.

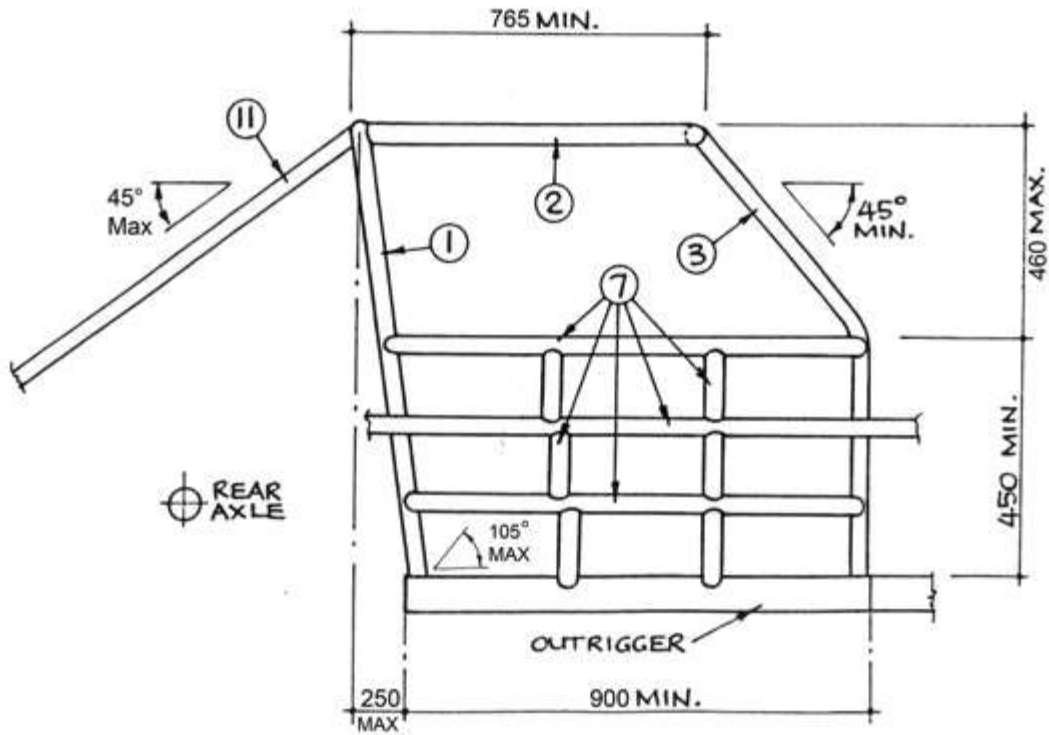

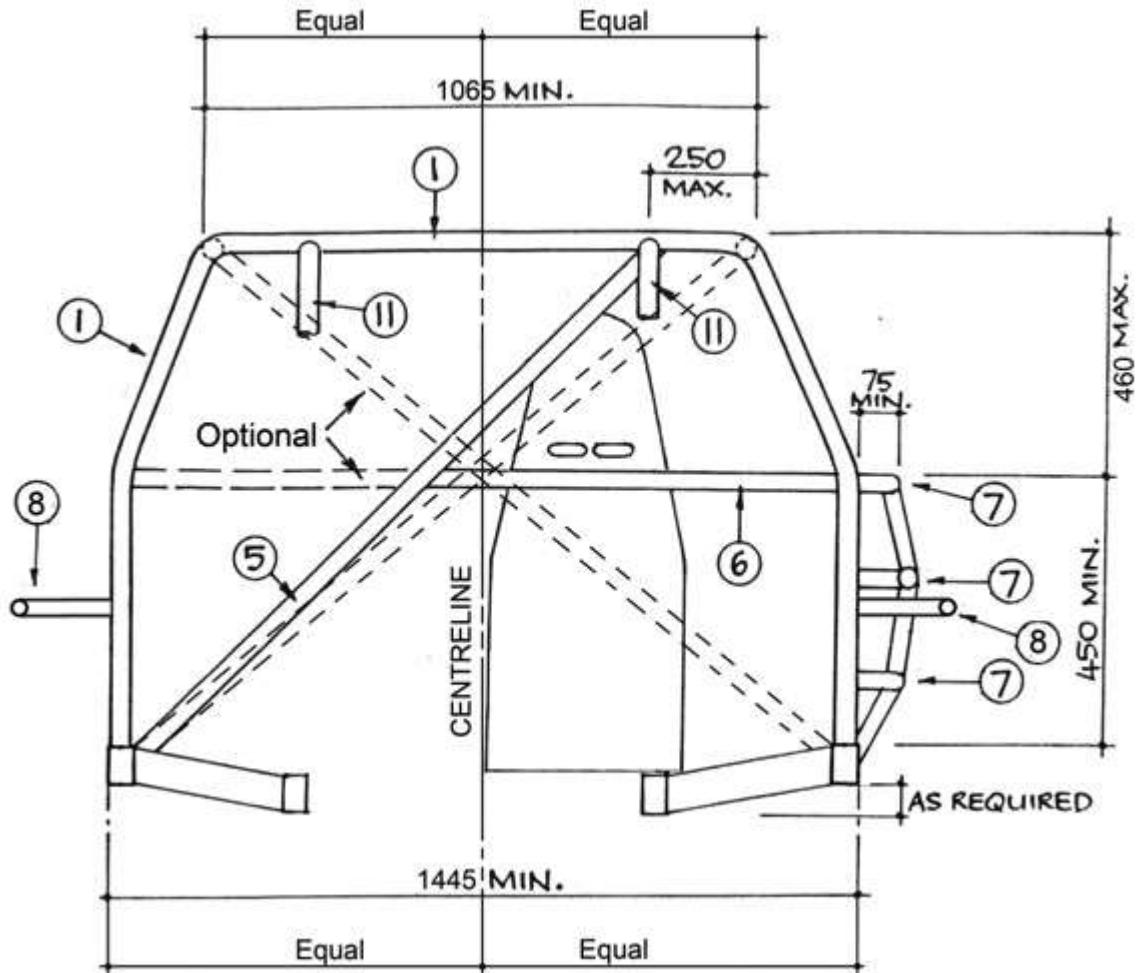

Note. Drawing for display purposes only. Refer to text for clarification on all drawings

Bolts shall not be used through structural tubing in the roll cage cabin area unless a welded sleeve is provided. No pop rivets, tech screws or self-tapping screws shall be inserted into roll cage tubing.

#### Chassis Cabin Width

Material: mild steel 75x50x3mm RHS minimum. The chassis outriggers shall be full width of the cabin area and be symmetrical along the cabin area centreline.

#### Front Chassis Rails

Material: mild steel 75x50x3mm RHS minimum. Front Chassis rails must extend forward of the front axle centerline minimum 380mm and shall be symmetrical to the cabin chassis area.

#### Rear Chassis Rails

Material: mild steel 75x50x3mm RHS minimum. Rear chassis rails must extend from the centerline of the rear axle rearward a minimum of 610mm and have the fuel tank mounted in this area. ie. Chassis rails must extend past the rear face of the fuel cell to protect the fuel cell in the event of an accident. The minimum distance between the inside face of the rear chassis rails as measured directly above the centre line of the rear axle shall be 736mm. (29inches.) Rear chassis rail location is not required to be symmetrical to the cabin chassis area. All material in fabricated chassis, chassis outriggers and/or sub-frames shall be minimum 75x50x3mm mild steel. Both chassis rails, fore and aft of cabin area, must be stepped a minimum of 75mm when viewed in side elevation to create a crush zone. Lightening of chassis material is not permitted.

**Chassis design options.**

Chassis shall be manufactured to comply with either design shown below.

Note. Drawing for display purposes only. Refer to text for clarification on all drawings.

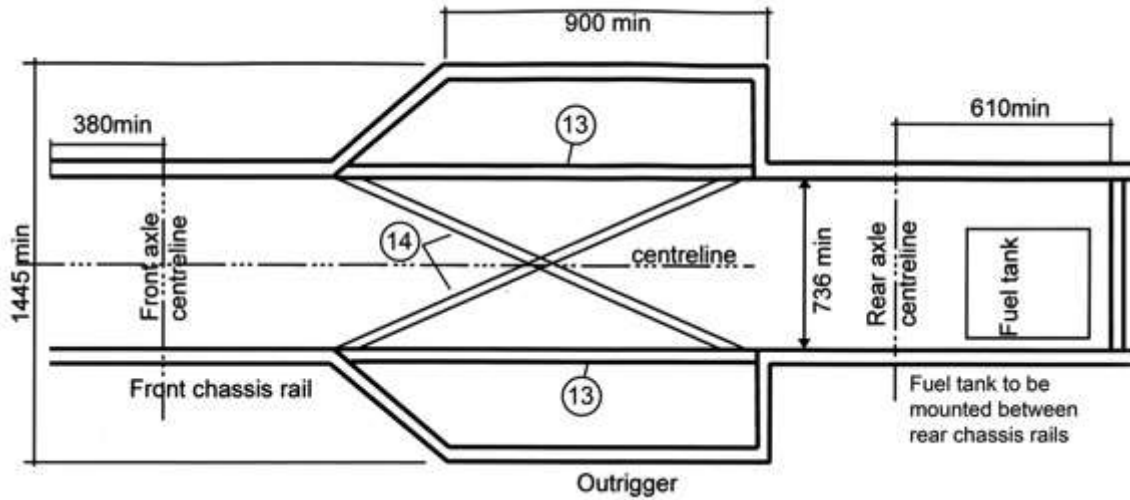

- (13) **Through Rails** – The through rails shall be 38x3mm CHS minimum, 40x40x3mm RHS minimum or 50x50x1.6mm RHS minimum.
- (14) **Crucifix** - The crucifix shall be 38x3mm CHS or 50x50x1.6mm RHS minimum. The crucifix shall terminate within 125mm of the outrigger.

Front chassis rails and outriggers shall be symmetrical to common centreline.

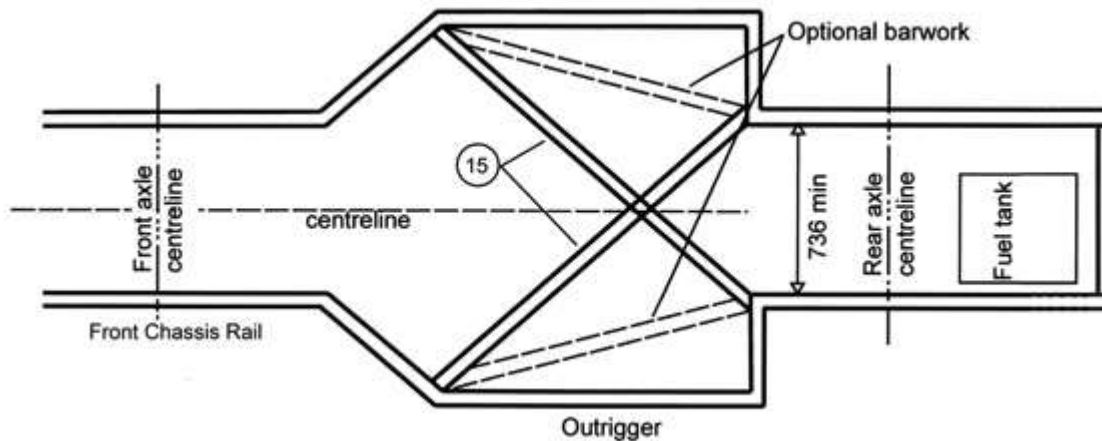

- (15) **Crucifix** – The crucifix members in the chassis design above shall be 50x50x3mm RHS minimum.

The chassis may be constructed as either the conventional design or the underslung design as shown below. Both styles must incorporate the minimum 75mm step in the chassis to create a crush zone.

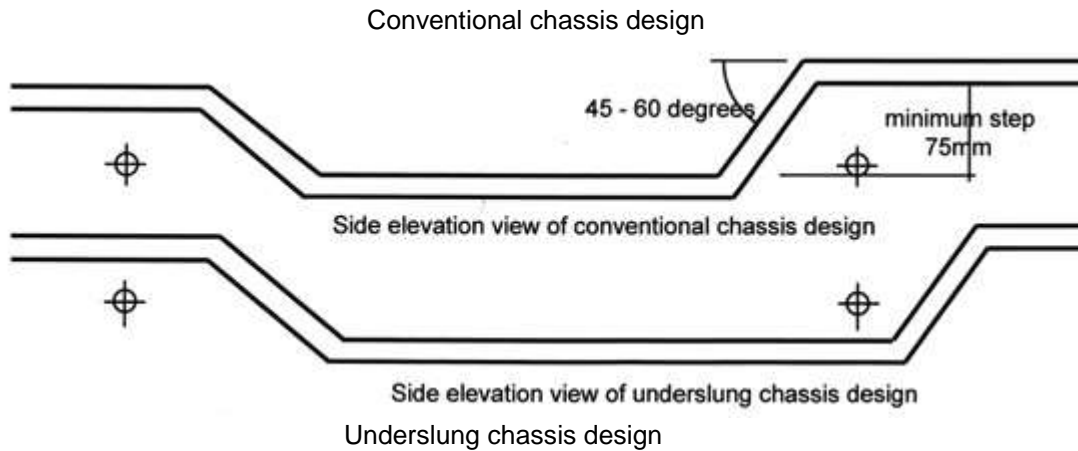

## 21. ANCILLARY BARWORK, PLATES AND BALLAST

### Ballast

Ballast must only be attached to either roll cage or chassis below deck height.

Ballast may be attached directly to the chassis by utilizing 12mm minimum high tensile bolts and Nyloc nuts either through a plate welded to the chassis or bolted through a sleeved insert in the chassis rail. If attached to roll cage tubing, proprietary mounting brackets shall be used. eg. AFCO, Bicknell etc.

Each piece of ballast shall be painted white and be permanently marked with registered car number for identification.

Ballast up to 305mm in length shall have 1 bolt into approved ballast brackets.

Ballast up to 610mm in length shall have 2 bolts into approved ballast brackets.

Ballast shall be limited to a maximum of four pieces per car.

Total weight of all ballast used at any one time shall not exceed 40kg.

### Quarter window bar

A quarter window bar, if required because of excessive rake or a long roll cage, be fitted to both sides and installed from the top NASCAR bar to top half of pillar bar using minimum 25x3mm CHS. Alternately, a 38x3mm CHS bar may be fitted from top of 'A' pillar bar to top of NASCAR bar at 45° of the top bar on both sides.

### Anti-spear plate

An "anti spear" plate, of 3mm steel or 5mm alloy, shall be fitted on the outside of driver's side NASCAR bars, from floor-line to the top NASCAR bar, forward of the first vertical door bar to the front leg of the roll cage. If not welded, a one piece external door plate shall be bolted on using 8mm high tensile bolts through a minimum of 6 – 50x50x3mm MS tags welded to the NASCAR bars.

If individual pieces are used, each piece shall be bolted with 8mm high tensile bolts through 4 – 25x25x3mm MS tags welded to the NASCAR bars.

### Head plate

The head plate shall fully extend from the main roll bar forward to the front roof hoop bar and from the side roof hoop bar across to the centre roof bar.

The head plate shall be 5mm ALUMINIUM ALLOY or 3mm STEEL and shall be securely bolted using a minimum of 10x8mm dia. high tensile bolts, 3 each side, 2 front, 2 rear, bolted through 50x50x3mm MS tags. Plate shall be mounted from above. Fig 4 (i)

A minimum 50mm clearance is required between the helmet and any part of the roll cage and head plate when the driver is seated.

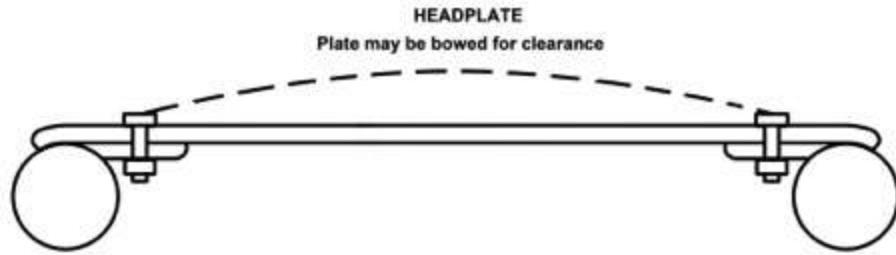

Fig. 4(i)

Alternatively, the head plate may be fabricated to provide head clearance as per Fig. 4(ii) below.

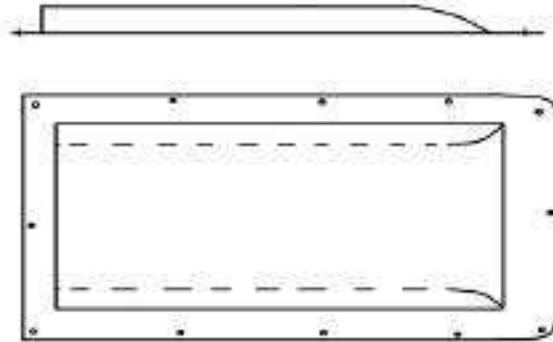

Fig. 4(ii)

### Bumper bars

Cars shall be fitted with a single tube style bumper front and rear. Bumper bars shall be manufactured using 38.1x 3.2mm CHS maximum. Bumpers are to remain hollow. Corners and ends of bumpers shall form a 100mm minimum radius.

Front bumper return shall be 300mm maximum, minimum 100mm. Rear bumper returns may be extended as a skid rail along the inside of body between bumper and wheel arch, and then extend inward to the chassis rails.

Bumper mountings to be of maximum 38x3mm CHS, 40x40x3mm RHS or 50x25x3mm, gussets shall not be used.

Maximum of four bumper to chassis mounting points for each bumper bar.

The rear of the bumper bar facing the chassis shall have 100mm minimum offset from the chassis rail. Fig. 5. Front and rear bumper must be inside of moulded panels. Front bumper bar overall width shall be 1960mm maximum.

Bumper mounts and supports shall be measured from the rear edge of the bumper.

Front bumper returns must be extended into the stay bars using maximum 25x25x3mm RHS or 25x3mm CHS





**Fig. 5**

Typical Right Rear bumper bar assembly.

Typical Front bumper bar assembly.

The bumper assembly shall be designed to provide a crush zone. No bar work shall be within 100mm of the rear face of either front or rear bumper bar.

#### **Fuel tank protection**

Bar work must be constructed of minimum 38x3mm CHS or 40x40x3mm RHS and have 25mm clearance around tank and filter. Protection bar is to prevent entry to tank by nose of another vehicle. Fuel tank protection bars must have radius formed corners as per diagram. No straight side pipes for jacking to extend below bottom member. Protector must be 25mm lower than an underslung tank and mounted as per Fig 6.

Brace bars to tank protector do not constitute bumper mounts.

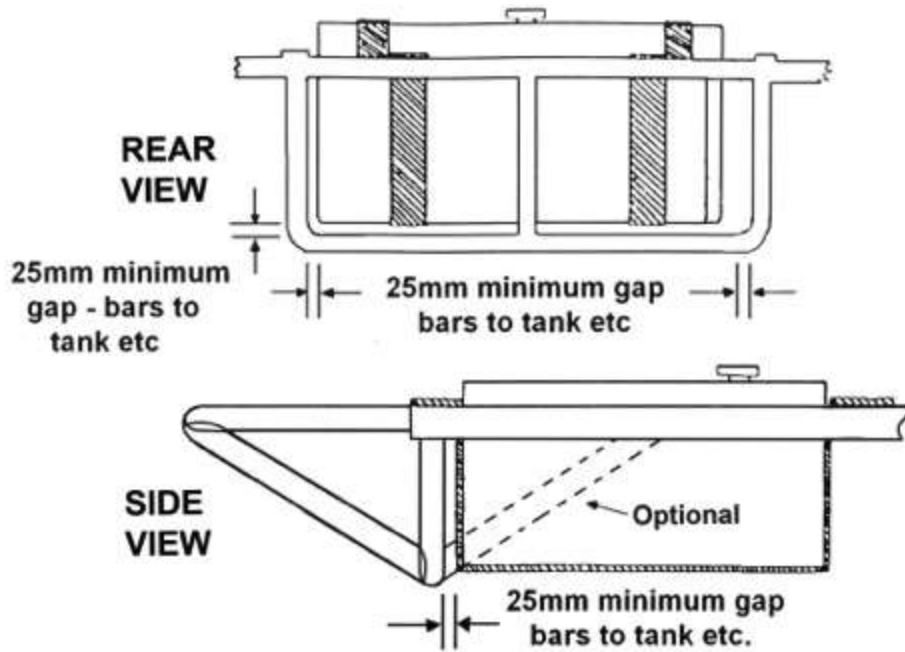
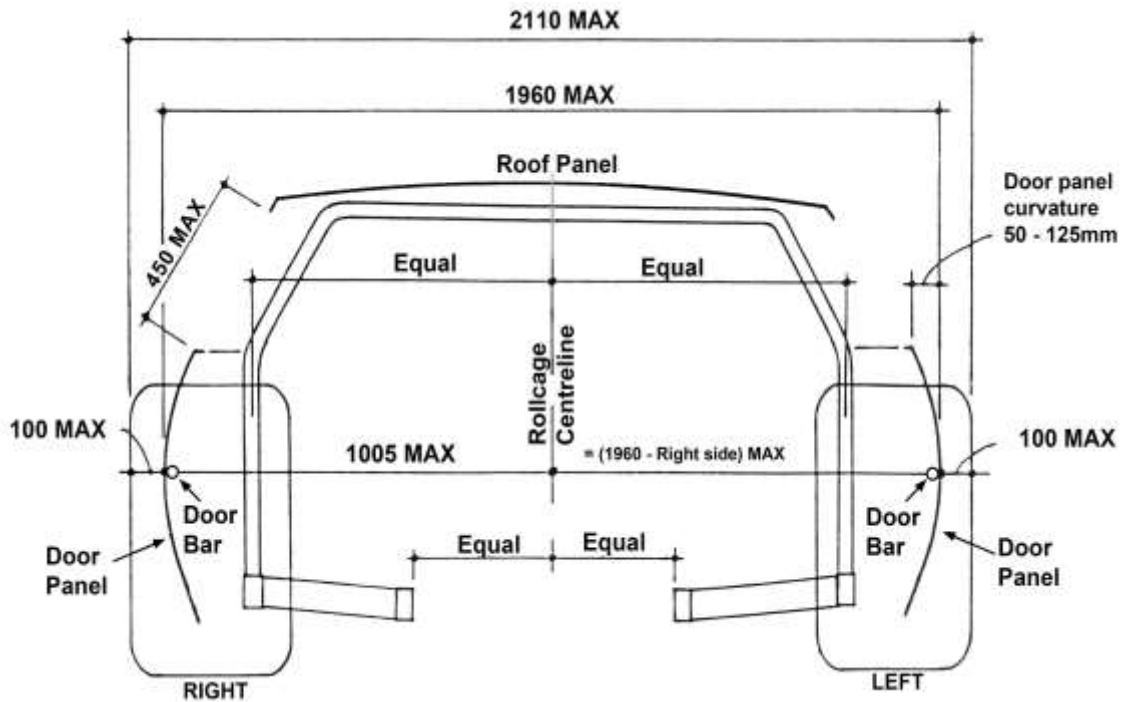

Fig. 6.

## 22. BODY SHAPE, DIMENSIONS AND BODY FITMENT

### General body fitment

Body is to be a complete outer shell and comply with the Super Sedan Body Measurements detailed below. It must be fitted so that the centreline of the body is within 25mm of the centreline of the chassis. The roof panel shall have a 50mm fall in all directions from the middle point. A straight edge placed across the roof panel from front to rear or left to right shall have a minimum of 50mm curvature on both sides. No laying back or flattening down of the plastic style nose cone. If using a MD3 nose cone, it must be of stock appearance and must not be wedged in any form and must have a convex shape when viewed from either side. Decals indicating make and/or model may be fixed to the vehicle in prominent positions.



**Fig. 7** (As viewed from the front)

The 1005mm measurement is derived by dividing the maximum body width (1960) by two (2equal halves) and then adding the 25mm body offset. This equals 1005mm. The maximum measurement for the left side can then be calculated by subtracting the 1005 from the maximum body width (1960) resulting in a maximum of 955mm.

The centerline of the chassis is the same centerline as the roll cage. The roll cage is symmetrical so therefore when the body is installed with a 25mm offset to one side, there can never be anymore than 50mm **difference** between the chassis to body measurements at the same point on either side. For example, the measurement for the roof panel to the roof hoop bar cannot be more than 50mm different on either side and the door bars cannot have more than 50mm difference when measured back to the rear main hoop bar.

All Bodywork, including any subsequent repair of race day damage, shall be to a professional standard. The vehicle shall be presented for racing in as near to original condition as possible after any racing accident.

Panels shall be attached using rivets, bolts and nuts or proprietary race fixings. No cable ties or race tape unless race night repairs.

All Super Sedans shall comply with the nominated body measurements. Body Width shall be measured with door panels pushed against door bars. Wheel offset shall be measured with door panel pushed against the door bar. Door bar location shall comply with Fig. 7 above.

All moulded plastic or fibreglass body panels must be complete. Rear quarter panels and the rear panel shall extend a minimum 100mm below the rear bumper bar. Side body panels must be parallel. No additional panels shall be fitted to provide an aerodynamic advantage.

The body shall be fitted in such a manner that it shall not be raked in any form and that the body runs parallel with the chassis.

Minimum radius on the top of the rear quarters, front guards, and door panels is 20mm.

Body is not to be higher than 38mm above the bottom of the chassis rail.

Drivers floor panel shall be minimum 1.6mm steel or aluminium and shall be fitted on top of chassis rails.

Deflection curve at top and bottom of each side panel relative to the waistline is to be 50mm minimum to 125mm maximum.

## Dimensions and measurement locations

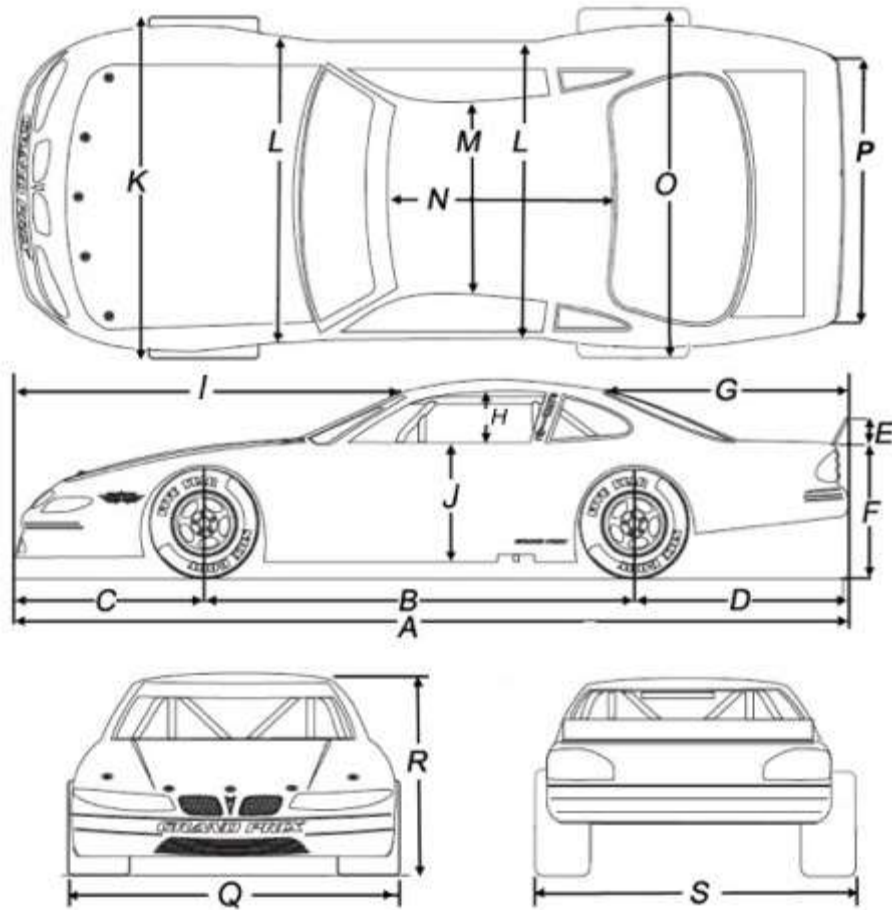

Dimension	Specification	
A	4900	Min
	5300	Max
B	2540	Min
	2740	Max
C	-	Min
	1250	Max
D	-	Min
	1300	Max
E	-	Min
	180	Max
F	-	Min
	1100	Max
G	-	Min
	1450	Max
H	-	Min
	450	Max
I	-	Min
	2550	Max
J	-	Min
	850	Max

Dimension	Specification	
K	-	Min
	2110	Max
L	-	Min
	1960	Max
M	1200	Min
	1400	Max
N	1050	Min
	1500	Max
O	-	Min
	2110	Max
P	Body width at that point or 1550mm whichever is the lesser.	
Q	-	Min
	2110	Max
R	1250	Min
	1400	Max
S	-	Min
	2110	Max

### Notes

Measurement F for Monaro only = 1200mm maximum.

Measurement P relates to the width of the spoiler blade. (1550mm maximum)

### Rear quarter window

Rear quarter window panel (as distinct from the straight drop on the RX8 from the back of the roof) should terminate at least 350mm in front of the base of the rear spoiler blade. The top edge of the rear quarter panel window shall form a straight line from the roof attachment point to the point of contact on the rear quarter deck. The window opening shall be a minimum of 1/3 of the height and 1/3 of the length of the window panel.

### Interior decking and firewall

Driver must be protected and isolated from mechanical, fuel, electrical and exhaust components by metal firewalls, minimum 0.9mm thick. Interior deck sheeting shall enclose the complete cabin area and shall extend through to the rear panel.

### Bonnet and Boot lids

Bonnet is to be securely fastened by five bonnet pins. Pins to be 12mm minimum to 15mm maximum mild steel or aluminium. Where a metal bonnet is fitted only 4 bonnet pins are required. Bonnet lock pins shall be 3mm minimum to 6mm maximum. Large reinforcing washers (30mm OD minimum) to be fitted to all bonnet pin holes.

Boot panel to be of profile and shape to match approved body measurements.

An access panel, 650mm x 300mm minimum shall be fitted to the rear deck panel and must allow access to fuel tank for scrutineering. A removable boot panel shall be securely mounted in four points. Hinged boot panel shall be secured in two points opposite the hinge joint.

Power bulges on the bonnet shall be limited to a maximum height of 100mm at any point above the bonnet. The "ears" on plastic fenders shall protrude a maximum of 100mm above the bonnet or mudguard panel at the point they contact.

Air cleaner may protrude through a flat bonnet to a maximum height of 100mm as measured by placing a straight edge across the top of both mudguards immediately in front of the air cleaner. The vertical distance from the underside of the straight edge to the top of the air cleaner housing shall not exceed 100mm. Maximum clearance around filter shall be 40mm.

### Rear spoilers

Rear spoilers are an optional fitting on a Super Sedan. The spoiler may be a single plane type generally found bolted directly to the rear deck or the dual plane/Super Car type mounted on supports above the rear deck. The spoiler blade is the flat inclined surface of the wing.

**(1) SINGLE PLANE** - Single plane spoiler shall be a maximum of 180mm high. A maximum of two supports are permitted between the spoiler end supports. All rear spoiler supports must taper to zero at the front and not project past the height of the blade. Shall comply with the dimensions specified in Fig. 8

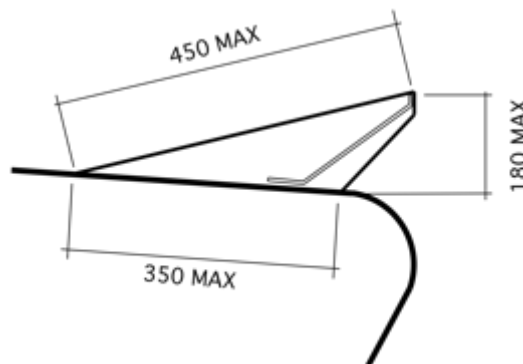
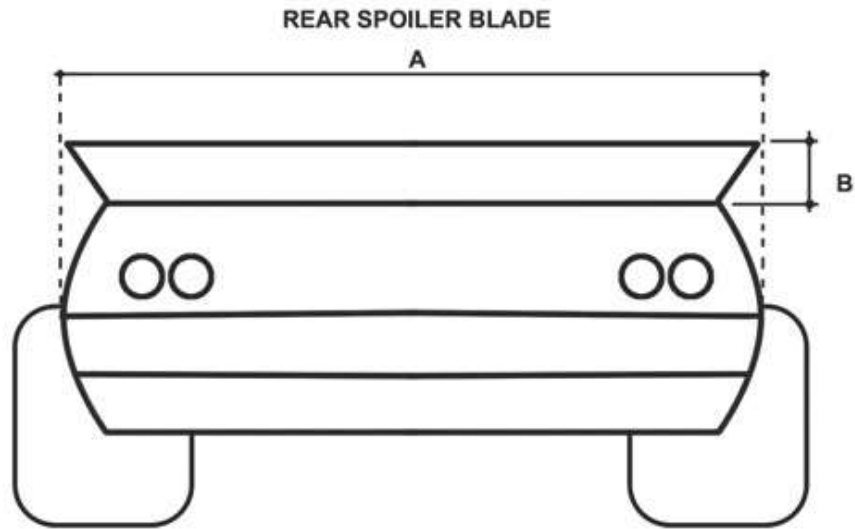

Fig. 8

No part of the spoiler shall extend past the bumper line (including corners) when viewed from above. 25mm partial folds on top edge of end supports of rear spoiler are permitted.

Spoiler blade shall be no wider than the body at that point. (e.g. if body at waist line on rear quarter is 1550mm wide then maximum width of spoiler above that point is 1550mm also) Fig 9.

The spoiler blade shall be one complete panel only. (no holes)



**Dimension A:** No wider than body waistline at this point  
**Dimension B:** Maximum 180 High including end support

Fig. 9

All blade supports shall be no higher than the blade

**(2) DUAL PLANE** - V8 Super car rear wings are allowed on Falcon, Commodores, and VX/VY Monaro only. End plates must be a replica/representative of V8 Supercar end plates.

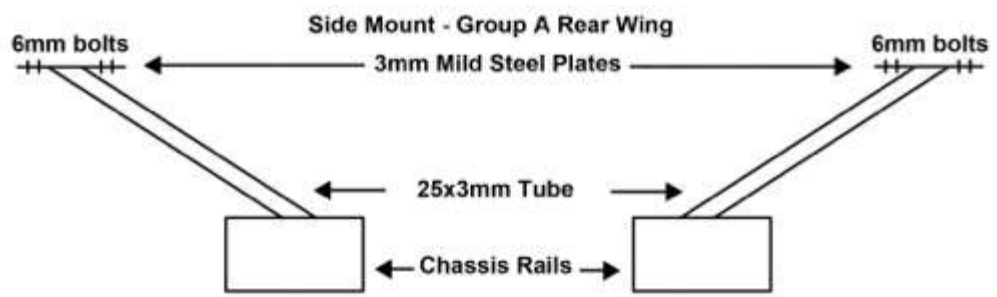

**Centre Mount - Group A Rear Wing Rear View**

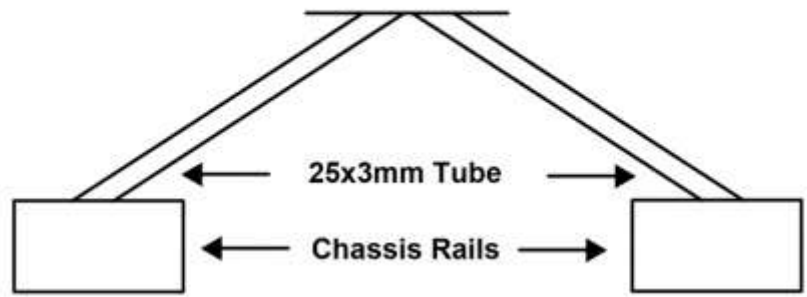

The blade must be the profile of the original V8 Super Car Wing. The wing shall be mounted on the rear of the car, no further back than the rear bumper bar. The blade shall not be wider than the waistline of the body of the car where fitted and must not overhang on corners. V8

Supercar rear wing must not overhang past the body panels and the rear bumper in any direction. The wing shall be attached with a minimum of two 6mm bolts per leg, making at least four bolts with substantial washers, at least 25mm diameter. These bolts shall attach through the boot lid or rear decking to 3mm plate. This 3mm flat plate shall be attached to the chassis using 25x25mm

mild steel. The 25mm tube and/or 25x25x3mm angle shall be welded to the rear chassis rails. The V8 Super Car rear wing fitted to Commodores and Falcons shall be no higher than 330mm above the boot lid, at the highest point. When fitted to a Monaro, the blade can be no higher than 180mm above the boot lid. Other aerodynamic aids not permitted.

### **Rub Rails**

Rub rails are an optional fit and must be made of a nylon (urethane, nolathane) rubbing strip 50mmx12mm maximum. These rub rails shall not be included in the overall body width measurement or the 100mm that the wheel can be outside the bodyline.

Rub rails must be securely mounted against body and through the door bar at a minimum of four points with equally spaced 8mm coach head (cup-head) bolts. Bolts at each end shall be no more than 50mm from the end of the rub rail. Rub rails are not permitted on the quarter panel behind rear wheel.

### **Towing attachments**

A wire rope or webbing strap shall be securely attached to the front and rear bumper bars. The wire rope or webbing strap shall protrude through a hole in the plastic nose or tail to allow a disabled vehicle to be towed.

### **Interiors and firewalls**

Driver must be protected and isolated from mechanical, fuel, electrical and exhaust components by a metal firewall minimum 0.9mm thick.

### **Presentation and Signwriting**

All paintwork, sign writing and numbers is to be neat, attractive and of a professional standard. All vehicles must carry the correct identification number as issued by their club. This number shall be displayed on each side of car and on the roof. In addition, a 150mm high number and prefix shall be placed on the tail of the car to help drivers line up when one-way communicators are used.

The name of the driver shall be displayed on the roof over RH door or on visor strip, in letters of a minimum of 75mm high.

Headlight and tail light apertures may be highlighted by decal or silhouetted to help identify make and model. Decals indicating make and/or model may be fixed to the vehicle in prominent positions.

### **Front windscreen mesh**

A 50x50x3mm steel mesh screen shall be securely fitted to roll cage in front of the driver. The windscreen mesh must be welded, or clamped with 4 metal clamps or bolts to the roll cage and cover the entire area between the "A" pillar and centre windscreen bar. A sun visor / mud protector cover strip may be fitted to the top and bottom of the mesh screen. No other window apertures shall be covered with any material except for the SFI approved window net on driver's window.

## **23. SUSPENSION**

### **Wheelbase**

Wheelbase shall be 2540mm minimum and a maximum of 2740mm.

### **Wheeltrack**

The front and rear wheel track width shall be 2110mm maximum and shall be measured across the top of the wheels to the outmost point on the sidewall of the tyres in the 12 o'clock position.

### **Steering**

Steering components must be in a sound condition. Steering joints to be split pinned or lock nutted as required. Steering column must be securely mounted to the roll cage dash bar. Hub of steering wheel must be padded with dense resilient foam and covered.

### **Spindles**

Offset spindles are not permitted. The top ball joint taper and the bottom ball joint taper on any spindle shall share a common centreline. The spindle snout centreline shall intersect the ball joint taper centre line.

## Suspension

Front suspension shall consist of a top A arm and a lower control arm as a minimum.

Lower control arms of front suspension shall not cross the centreline of the car.

Front mountings of forward facing rear trailing arms and leaf springs are to be boxed in on the right hand side to protect the driver.

Adequate side support shall be provided on 5th Arm assembly to alleviate sideways movement of the arm. A 40x5mm FMS or equivalent CHS tube shall be installed beside the seat to protect driver from 5th arm if diff is dislodged. Fig. 10(i) & 10(ii)  
Arm and Coil unit are to be behind firewall.

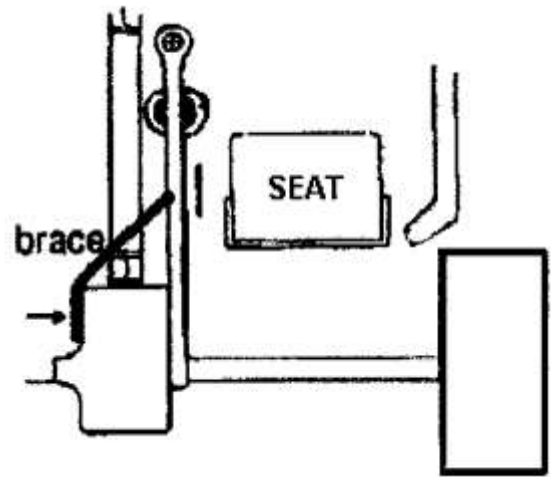

Fig 10(i)

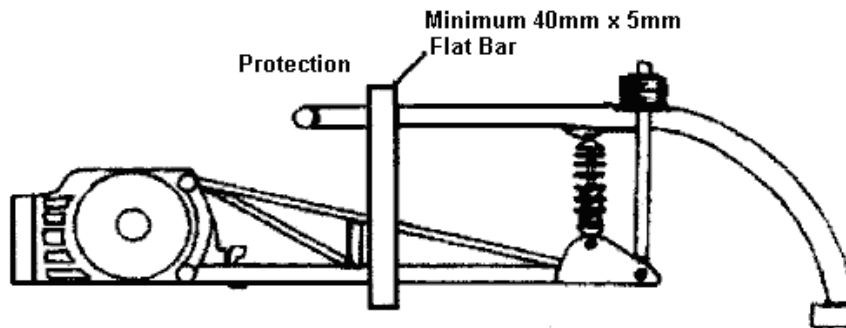

Fig 10(ii)

## Panhard Bar

Any adjustment of the panhard bar shall be by mechanical means only whilst the car is stationary prior to the event. Provision for panhard bar adjustment whilst the car is in motion or from the driver whilst seated in the cockpit or by any other means whatsoever shall not be permitted.

## Shock absorbers

Shock Absorbers are limited to a maximum of one external compression adjuster and one external rebound adjuster and shall not have any form of remote canister attached in any manner whatsoever. No mechanisms are permitted to allow adjustments to be carried out from the cabin or driver's seat. The adjustment of shock absorbers is not permitted once car is formed up on the dummy grid.

## Brakes

Foot operated, hydraulic brakes are to be fitted and be effective at race speeds. Bias adjustable brake systems are permitted although 'electronic' anti-lock brake systems (ABS) not permitted. Brake bias and brake shut off valve operation is permitted from the driving compartment only. Brakes are to be fitted to a minimum of three (3) wheels. A single brake assembly mounted on a ONE-PIECE (live) rear axle is considered to be brakes fitted to two wheels. Maximum of one brake caliper shall be fitted per wheel.

Carbon fibre/titanium brakes and components not allowed.



## **24. ENGINE AND ENGINE SYSTEMS**

### **Engine options for Super Sedans**

A Super Sedan shall use one of the following engine types:

V8  
V6 or inline 6  
Rotary

Engines must be sealed using two SSA numbered seals and 1 yellow identification seal. Sump and timing cover to be sealed.

An inline 6 cylinder engine may be laid over to permit mounting of supercharger/ turbo under the approved 100mm power bulge. In all other cases, vertical remains vertical etc., spark plugs in Rotary engines remain horizontal and vee engines are to be balanced against a vertical centreline.

Oil reservoirs, remote oil filters, coolers etc., must be: securely mounted under deck level and be isolated from driver. All connecting hoses, couplings etc., are to be correct class of fittings for the purpose.

Multiple register, non actuating/non controlling recording equipment including instruments that supply on-board only engine rpm, rev limiter, oil pressure, fuel pressure, coolant temperature and lambda information are permitted. (eg. electronic dash and RPM type displays)  
Multiple register recording data logging devices that include programmable electronic control units (ECU) are not allowed on V8 engines but may be used with 6 cylinder and Rotary engines. Wheel speed and/or rotational speed sensors are prohibited.

### **Engine block**

The definition of a V8 block is any block that was commercially produced and was readily available to all competitors at the time of manufacture. Aluminium V8 engine blocks are not permitted. V8 and V6 engine blocks shall have a maximum bore spacing of 4.46 inches and a maximum block deck height of 9.5 inches. The block height is measured from the crank centre line up through the bore to the mating face of the deck. All engines must have a number stamped on the block. (No two engines shall have the same number)

Maximum engine capacity after all modifications shall not exceed 367cu.in.

Maximum capacity for cars with 6 cylinder forced induction engine shall be calculated by dividing the maximum V8 engine size by 1.5. Eg. 367 divided by 1.5 = 245 cubic inch

### **Cylinder heads**

A Super Sedan shall use any cylinder head that was commercially produced and was readily available to all competitors at the time of manufacture.

V8 and V6 cylinder heads shall have a maximum of 2 valves and 1 spark plug per cylinder.

Overhead camshafts are not permitted on V8 or V6 engines.

Inline 6 cylinder engines are permitted a maximum of 2 camshafts, 4 valves and 1 sparkplug per cylinder. Overhead camshafts are permitted on inline 6 cylinder engines.

### **Crankshaft and Conrods**

Crankshafts and conrods may be lightened and balanced. No titanium cranks or con rods allowed.

### **Carburetor and Induction systems**

V8 Super Sedans shall only utilize a single 4-barrel carburetor as a sole means to deliver any form of fuel or air fuel mixture to the engine. It shall have all working parts in use, e.g. needle and seat, fuel bowl, float, jets and the fuel is to be delivered to the main jet by atmospheric pressure. Rotary engines with MORE than two rotors are restricted to a single 4-barrel carburetor.

Twin rotor Rotary engines and 6 cylinders may use carburettor/s or fuel injection and forced induction.

Return springs must be fitted to each butterfly shaft (inbuilt throttle springs acceptable), and one spring to accelerator pedal linkage

### Ignition

Ignition systems must not contain or actuate any traction control function.  
The SSA reserves the right to download information.  
Kill switch to be clearly marked for method of operation e.g. DOWN/OFF

### Fuel

Methanol or petrol may be used. (maximum specific gravity of 0.820)  
The introduction into the combustion chamber/s of nitrous fuels and/or additives, either in solid, liquid or gaseous form, (e.g. nitrous oxide) by any means whatsoever, is expressly forbidden.

### Exhaust system

Exhausts must comply with local noise level requirements. Maximum 95 dBA.  
All exhaust gases to be directed away from all drivers, fuel tanks and tyres.  
Internally ducted exhaust system may vent through the body, maximum 150mm above chassis.  
Exhaust system to have maximum of two outlet pipes, and not protrude beyond bodyline. Fig. 11  
Trim plate material shall be maximum 1.6mm aluminium.

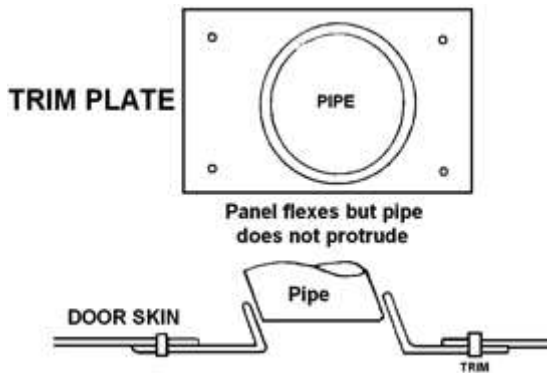

Pipes and mufflers must be securely attached to the vehicle.  
Any car exhausting excessive unburnt Methanol fumes while on dummy grid, or being formed up on the track may be excluded as this constitutes a health hazard

Fig. 11

### Cooling system

Cooling system to have a manual pressure relief tap or lever vent type cap fitted with a hose to direct steam to the ground.  
All radiator hoses to be of fabric reinforced material, plain moulded rubber hoses not permitted.  
Radiators may be mounted inside cabin area provided that they are mounted below the deck sheeting to provide isolation from the driver  
All water pipes are to be securely mounted within the roll cage.  
A metal and/or plastic cover shall be installed over the top of the fan blades. The cover shall protect an area the full width of the fan blades and from the back edge of the radiator to the back edge of the fan blades. Alternatively, the fan may be encased with a full shroud.

### Engine position

Engine including cylinder heads and rocker covers shall be totally mounted inside the front chassis rails.

**Rocker Cover / Cylinder head must be inside L/H chassis rail**

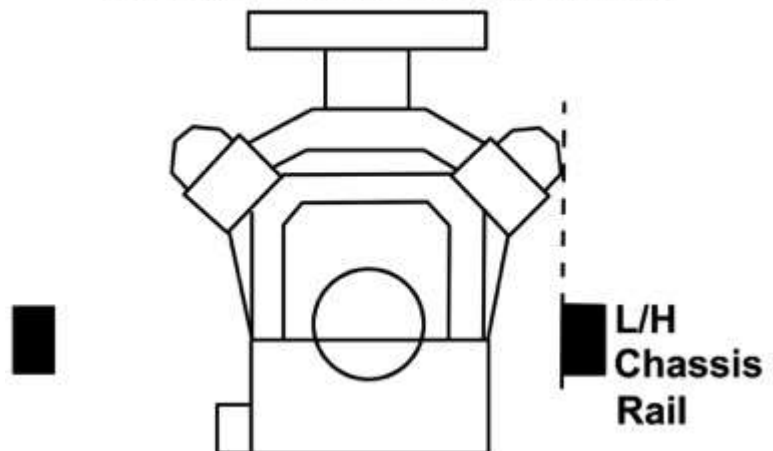

### Engine Setback

Measured from the centre of both top ball joints on the front end to the forward side of the engine plate as measured parallel to the centre line of the car. If there is no engine plate or the engine plate is not straight, measure to the rearmost mating face of the engine and the foremost mating face of the transmission. Either measurement shall not exceed the maximum allowed.

Engine setback for V8, V6 and Rotary engines is 660mm (26 inches) maximum.

Engine setback for inline 6-cylinder engine is 813mm (32inches) maximum.

### 25. TRANSMISSION, WHEELS AND TYRES

Electronic Traction Control systems of any type are not permitted.

Gearbox must have a minimum of two forward gears and a reverse gear.

Every racecar shall to be fitted with a functional clutch that allows the engine to be started before the transmission is put into gear to move forward or reverse.

### Scatter Shield

Cars not using a Bert or Brinn style gearbox must fit a scatter shield to protect the driver's feet and legs.

### Tail shaft

Tail shaft loops shall be a minimum 40mm x 5mm FMS or 6mm chain or 6mm wire rope. Tail shaft loops shall be fitted within 150mm of universal joints at the front and the rear of the tail-shaft to prevent the tail-shaft from dropping in an event of breakage. Tail shaft and universal joints to be correctly phased and be suitable for the application. Carbon fibre tail shafts are not permitted. Tail shaft shall be painted either white or a bright luminous colour.

### Wheel studs

Shall be Grade 8 and 12mm diameter minimum.

Titanium axles not permitted.

### Wheels

Alloy or steel wheels are permitted.

Maximum width of wheel is 12in (305mm) including bead lock attachment. Fig. 12

Wheels must be in good condition and free from cracks.

Dual bolt pattern drillings only permitted on Wide 5 style wheels.

Balance weights to be securely fastened or taped.

Removable wheel covers are allowed.

Wheels using centre-lock retainer nut must also use an approved locking device to prevent nut from being spun off. Forward rotation of the wheel must tighten the nut.

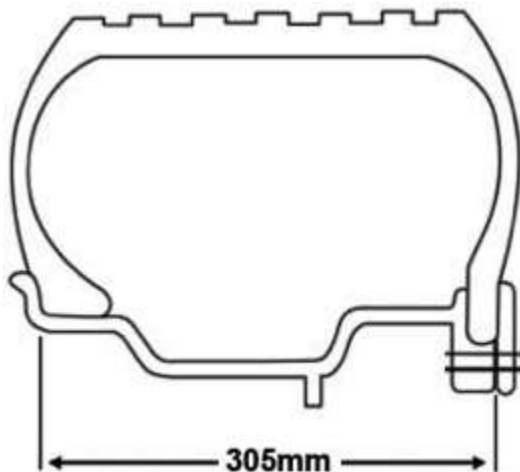

### TYRES

Lubrication of any type (grease or oil etc.) is not permitted on tyre walls. Tyre treatments that soften tyres are strictly prohibited.

Tyre shine type cosmetic products are permitted for application to sidewalls only.

Fig. 12

### Wheel spacers

A maximum of 2 (two) wheel spacers up to a maximum of 3 (three) inches wide may be used on any wheel provided that all specified body and chassis dimensions are complied with.

## **26. BATTERY AND ELECTRICAL SYSTEM**

Battery size shall not exceed 310mm long x 185mm wide x 220mm high.

Battery must be securely mounted in a box or steel frame secured to the roll cage or chassis.

Terminals and electrical cables shall be suitably protected to reduce arcing in the event of an incident. Suitable grommets must be fitted where battery cable passes through metal firewalls.

At the commencement of a meeting, car must be capable of starting with starter motor.

Switches: Ignition switch and electric fuel pump switch, if fitted, must be grouped together and be clearly marked. An engine 'KILL' switch, suitably marked, must be fitted in top deck panel.

Electrical switches shall NOT to be mounted through the floor.

Transponders must be mounted maximum 450mm forward of the front axle centreline on the front chassis rail.

## **27. FUEL CELL AND FUEL SYSTEM**

Maximum fuel cell capacity shall be 72 litres for petrol or 140 litres for methanol.

Use of cooling systems for fuel not permitted.

The area beneath cell must be open. Pressurised fuel cells NOT permitted. Fuel tap is to be marked indicating FUEL and the positions of ON/OFF.

Filler cap shall provide a positive seal and be inside body and behind a firewall. Levers of cam lock caps to be clipped closed. Proprietary aluminium and/or steel fuel cells are permitted but must include a bladder. Fuel cell is to be securely mounted entirely between the chassis rails behind rear axle centre line in a suitable steel cradle attached to the chassis or cage bracing, with a minimum clearance of 150mm forward of the rear bumper and 300mm minimum from the side of the vehicle. The fuel cell shall be isolated from the driver by a metal firewall.

The lower half or load bearing section of the cradle shall be constructed from a minimum 40x3 FMS or 19x19x1.6mm RHS, SHS or CHS. The straps over the top shall be 32x3mm FMS minimum. Fuel cell vents shall be fitted with an anti-spill device.

A flexible fuel line section must be fitted within 75mm of fuel cell and all fuel lines to be securely fixed in position. Barbed fittings of the correct size must be used in conjunction with screw type clamps when connecting flexible fuel line, exception being genuine SAE R6 lines and fittings.

Neoprene, reinforced plastic or 'black fuel line' may be used.

The fuel line to the engine must be fitted with a quick action NON-LEAK fuel tap, in working order, securely mounted within easy reach of driver and crash crew, and clearly marked FUEL ON-OFF positions. Return lines to the tank are to be fitted with a 'one way' valve.

Electrical fuel pump must be isolated from the driver by a firewall, be fitted with an independent earth to case, and be switched off by the KILL switch and by an engine monitoring relay.

An earth strap must be fitted from the plastic fuel cell filler neck to rollcage or chassis as an earth to prevent buildup of static electricity.

Fuel lines shall be isolated from electrical wiring.